

CNC PRECISION FIXED ANGLE VISE

Model: HPAV-130, 160, 160L, 200

- This vise has the same features as model HPAC above but has standard clamping screw instead of the MULTI-POWER SYSTEM.

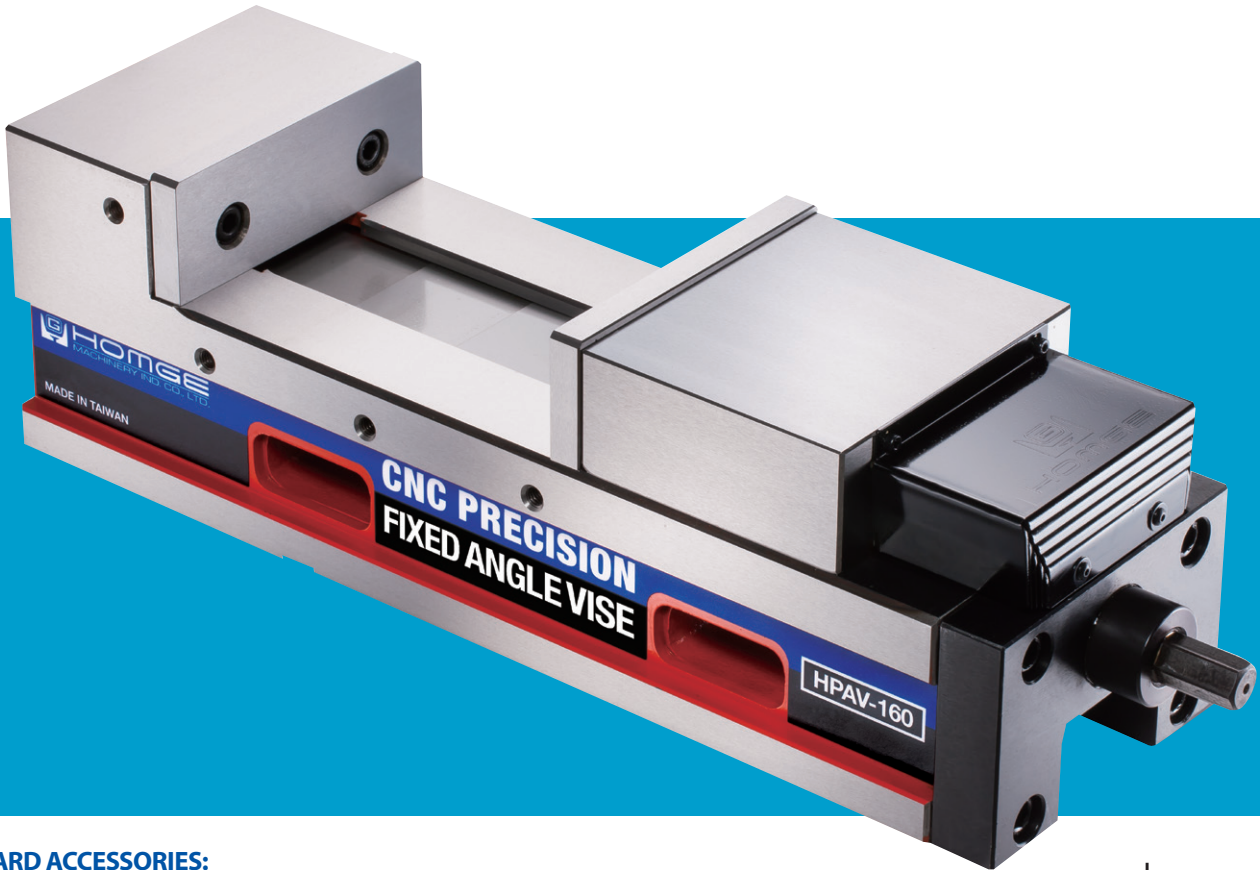

STANDARD ACCESSORIES:

- 2 pcs of Alignment Wedge
- 4 pcs of Clamp
- 1 pc of Handle

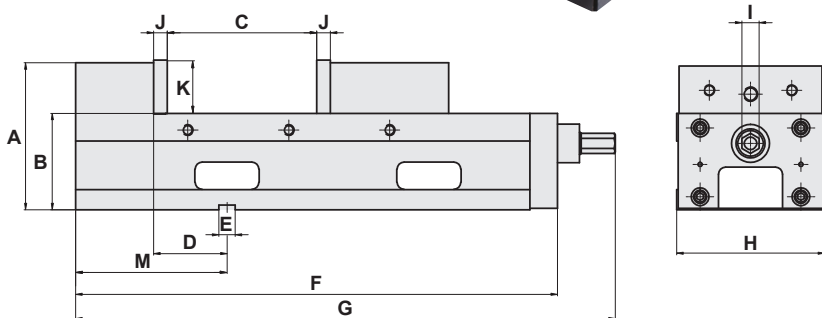

SPECIFICATIONS (Material: FCD 60 Ductile Iron. Hardness: HRC 50°)

Unit: mm

Model	A	B	C	C1	C2	C3	D	E
HPAV-130	147	95±0.01	0-190	70-260	115-305	185-375	80±0.02	18
HPAV-160	160	105±0.01	0-250	85-325	140-375	220-460	80±0.02	18
HPAV-160L	160	105±0.01	0-300	85-375	110-395	190-480	80±0.02	18
HPAV-200	170	110±0.01	0-290	90-380	155-440	240-530	100±0.02	18
Model	F	G	H	I	J	K	M	Weight (kg)
HPAV-130	440	503	131	19	15	55	150	42
HPAV-160	525	588	161	19	15	58	165	60
HPAV-160L	545	608	161	19	15	58	165	62
HPAV-200	600	662	201	19	18	63	197	90